



BL AM

Depureco Industrial Vacuums USA

19121 Marketplace Avenue, Building 1, Suite 165
Plum Creek Business Park • Kyle • TX 78640

www.depurecousa.com
info@depurecousa.com

2 HP
POWER

2325 in²
FILTER

11 gal
CAPACITY

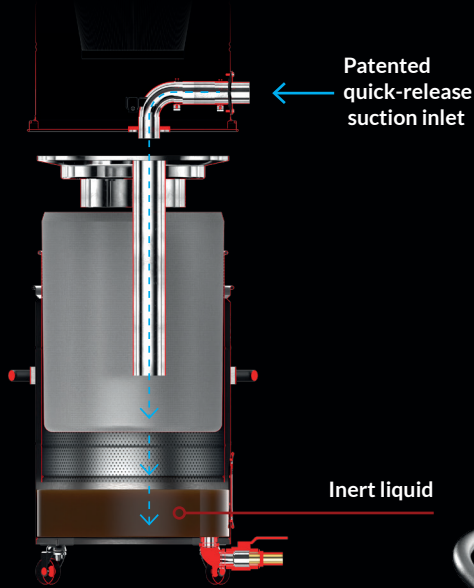

AVAILABLE WITH
**BRUSHLESS
MOTORS HEAD**

STANDARD HYDROGEN VENT
Pressure relief valve



**PATENTED CONNECTION
AND QUICK RELEASE
SYSTEM OF THE
IMMERSION NOZZLE**



**COMPLETE GROUNDING
OF THE UNIT**



**INERT LIQUIDS BIN
WITH INSPECTION
WINDOW**

**STAINLESS STEEL
AISI 304**
Lt **45**



**LIQUID DISCHARGE
VALVE**

HIGHLY TRANSPORTABLE

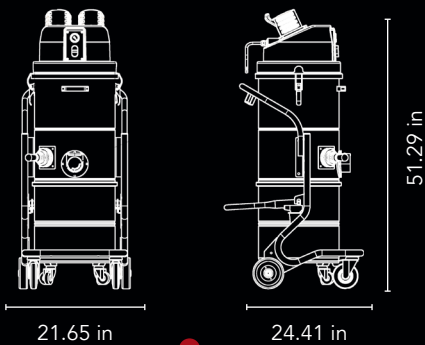

Weight: 99 lbs

DETACHABLE BIN



ATEX Marking:
II3GD Ex tD IIIC T135°C DC

SPEC SHEET

		Units	BL 45 ATEX Z22
Suction type			Brushless motor
Atex Marking			II 3 D Ex htc III B T284°F Dc
Power		HP	2 1 ~
Voltage Frequency		V Hz	120 50
Maximum vacuum		inH2O	92
Maximum air flow		CFM	129
Inlet		Ø in	2.75
Noise level - (EN ISO 3744)		dB(A)	72
Bin capacity		gal	11
Dimensions		in	21.65 x 24.41
Height		in	51.29
Weight		lb	99
Primary filter			
Type			Star filter
Surface area		in ² in	2325
(Class EN 60335-2-69)			M Class
Media			Antistatic polyester
Filter cleaning			Filter shaker
Absolute filter - Optional			
(Class - EN 1822)		in ²	H14
Media			Fiberglass
In suction			Opt H14
In suction			E10
Engine air inlet cooling		in ²	E10
Outgoing engine air cooling			E10

ACCESSORIES



ATEX STARTER KIT Ø 1.75 in



ATEX KIT PRO Ø 1.75 in

OPTIONAL



CYCLONIC SEPARATOR